

MS325 V6.0 Technical Specification

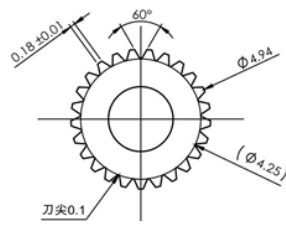

25T 5mm Output Shaft Spline

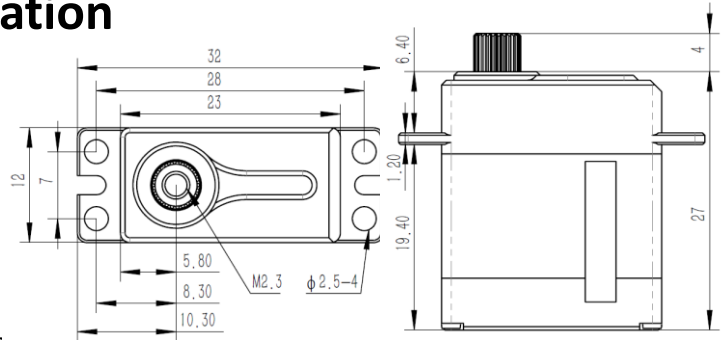

1. Operating Data

MS325 V6.0	
Rated Voltage	DC6.0V
Voltage Range	DC6.0V-8.4V
Stalling Torque	38N.cm@6.0V
	46N.cm@7.4V
	52N.cm@8.4V
No-load Speed	0.09sec/60°@6.0V
	0.08sec/60°@7.4V
	0.07sec/60°@8.4V
Working Frequency	1520us/20kHz
Default Travel Angle	±100°=200° Total
Temperature Range	-20°C+65°C
Soft Start	Programable
Programable	Yes
Case Material	Aluminum Alloy
Motor Type	Coreless DC Motor
Gear Set Material	Hardened Steel
Position Sensor	Contactless
Case Dimensions	23mm*12mm*27.5mm±0.2mm
Weight	20g±10%

2. Performance

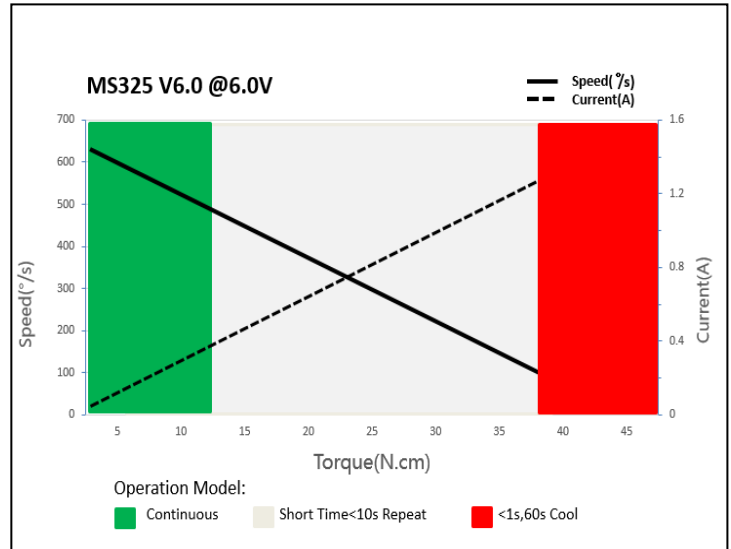

3. Command signal

PWM Command Interface

Signal Voltage	HIGH: min.3.3V, max.5.0V Low: min.0.0V, max.1.5V
Pulse Lengths	500us-2500us
Pulse Lengths for Position	500us/1500us/2500us -100°/ 0°/+100°

4. Electrical Connection

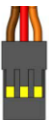
 3 2 1	Pin Assignment			
	1	Orange	Signal	PWM Command
	2	Red	DC+	Supply Voltage
	3	Brown	DC-	Supply Ground